



KONICA MINOLTA

SPECTROPHOTOMETER CM-3600d

Built for Precision,
Priced for Economy



New Enhanced Performance Technology teams patented performance features with simplified design and advanced cost-reducing manufacturing techniques.

The result:

- A highly accurate, reliable, rugged spectrophotometer.
- Versatile enough for all colorimetric applications.
- Simplified operation.

And

- LOW PRICE

Technology

KONICA MINOLTA Innovative Optical System "World first" technology :

- Numerical Gloss Control measurement within a few seconds.
- Numerical UV Control for calibration and measurements.
- Soft-flash mode to avoid triplet adsorption in fluorescent materials.

The essentials of imaging

The Innovative CM-3600d Spectrophotometer Brings You Highest Quality Levels in Color Measurement along with Unsurpassed Versatility, User Comfort and Low Cost!

Enhanced Performance Technology Konica Minolta Innovative Optical System

The CM-3600d is equipped with Minolta Innovative Optical System technology. For users, this means high accuracy and repeatability, improved performance, additional features, simple operation, and - low, affordable pricing.

This technology also provides:

1. Numerical Gloss Control

Instead of using a mechanically driven gloss trap, the CM-3600d is equipped with a patented numerical Gloss (SCI/SCE) control system. By sequentially firing two flashes, within a few seconds the system provides both SCI and SCE values for each sample.

SCI specular component included
SCE specular component excluded

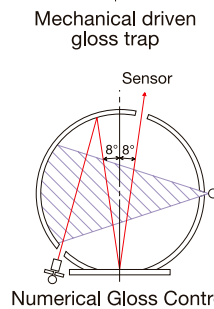
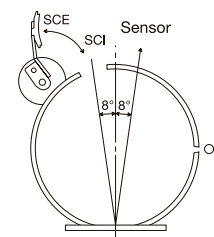
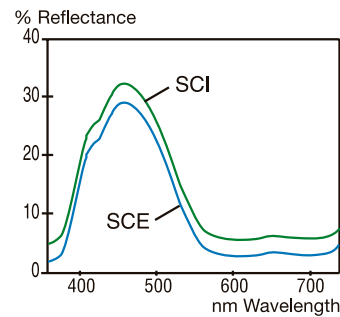

2. Numerical UV Control

To replace the time-consuming traditional UV measurement system that utilizes moving filters, the CM-3600d introduces yet another patented numerical calculation system, never seen before: The measured values of two sequentially fired flashes, one with full UV energy and one with UV cut-off filter at either 400 or 420 nm are combined to obtain the spectral characteristics, and the respective whiteness and tint value of any UV-activated fluorescence sample. To avoid triplet effect on FWA treated samples, the CM-3600d can be set to Soft-Flash mode. Numerical UV Control technology makes faster, more effective and reliable measurements of FWA treated materials such as textiles, papers and detergents.

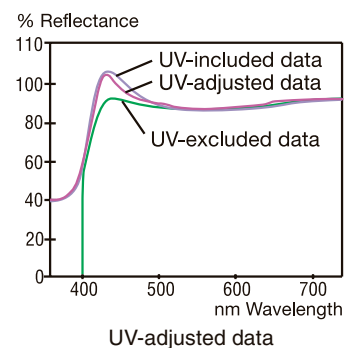
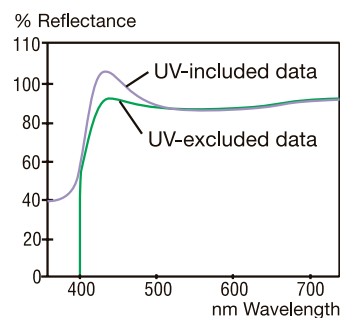
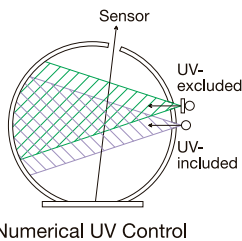

For high-accuracy color control
The newly designed Monolith Polychromator Unit

consists of a diffraction grating with a full wavelength range, 360-740 nm, at 10nm pitch, and 10nm half-band width, both for sample and reference light, and dual-channel sensor array.

Full range of application coverage

Whatever your sample looks like, with the CM-3600d you can measure it! Reflectance of opaque samples, Transmittance of transparent liquids or solids and Diffuse Transmittance of translucent materials such as plastics - the CM-3600d is truly versatile.

Transmittance Measurement-The CM-3600d employs the d/0° geometry (diffused lighting, 0° viewing), which conforms to ISO, DIN, CIE, and ASTM standards.

Reflectance Measurement-The CM-3600d employs d/8° geometry (diffused lighting, 8° from normal viewing) which conforms to JIS, ISO, DIN, CIE and ASTM standards.

Konica Minolta Innovative Optical System Technology

Konica Minolta's Innovative Optical System, including Numerical Gloss Control and Numerical UV Control, opens the way to unlimited application versatility at a price level never seen before.

Multiple measurement area selection

To cover all kinds of samples, the CM-3600d gives you the choice among three aperture sizes: LAV 25.4mm, MAV 8mm and SAV 4mm with precise measurement spot adjustment by a motorized observing lens.

Compact but yet Powerful

Behind the compact and space-saving design, you'll find the skills of a top-class instrument with 6" large sphere and other functions so far only found in much larger and more expensive instruments.

Maintenance free technology and ruggedness concept

The CM-3600d is equipped with maintenance-free technology and solid state components to withstand rugged conditions. The monolith polychromator unit assures highest durability and stability. With one exception (Observing Lens), the CM-3600d does not use any moving parts. Furthermore, each CM-3600d passes a hard endurance test program to comply with KONICA MINOLTA's highest quality standards in accordance with ISO-9001.

Bright and clear sample viewing system

The retro mirror's reflected and illuminated sample viewing screen minimizes fatigue and allows trouble-free sample observation.

Designed to meet your highest ergonomic expectations

The compact and space-saving body as well as all functions of the CM-3600d have been designed to ensure easy and fatigue-free operation in daily use. The bright mirror sample viewing system, the sample holder for up to A4 size samples with full 90° lock down, and the versatile Transmittance chamber for liquid or translucent samples are all just where you expect them to be for easy operation.

Performance

- Fast, simultaneous measurement of Specular Included and Specular Excluded components (SCI/SCE)
 - Fast, Instantaneous numerical UV adjustment enables UV-included, UV-excluded, and UV-adjusted data to be obtained simultaneously
 - Precise inter-instrument agreement.
- All CM-3600d's meet published inter-instrument agreement.

Versatility

- Full wavelength range 360-740nm with 10nm pitch
- Large (6") sphere; d/8° geometry
- Reflectance and transmittance sample measurements
- Changeable measurement areas (ø4mm, ø8mm, or ø25.4mm)
- View finder design for easy sample viewing
- Compact and lightweight

Reliability

- High reliability design with fewest moving parts of any benchtop spectrophotometer

SpectraMagic Ver.3.* (Optional)

Supports Windows® 98/2000 and Windows NT® 4.0

Full capabilities with SpectraMagic Windows® Quality Control Software

With the new Windows based Quality Control Software SpectraMagic, you can enjoy all capabilities of the CM-3600d. The advanced Device Driver Interface works perfectly with all numerical control functions like Numerical Gloss Control and Numerical UV Control. The modern Software design allows maximum freedom for numerical and graphical data display in various colorimetric systems and indices for any application in any industry. Newest tolerance calculation methods, customized printouts and data export to Calculated Results and From Database are just some examples that make SpectraMagic the perfect tool for total color control with all KONICA MINOLTA Spectrophotometers, including the new CM-3600d.

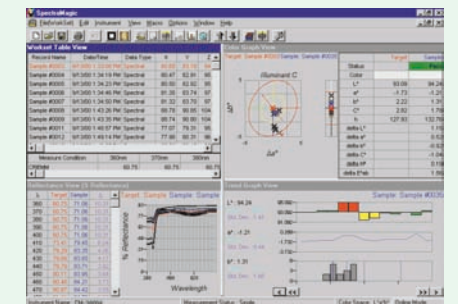
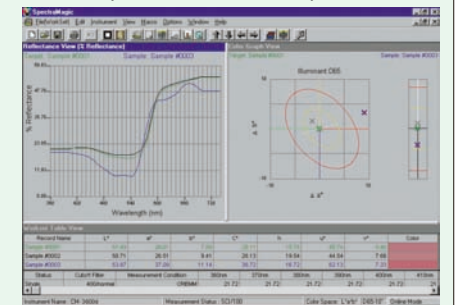

Dimensions (Units:mm)

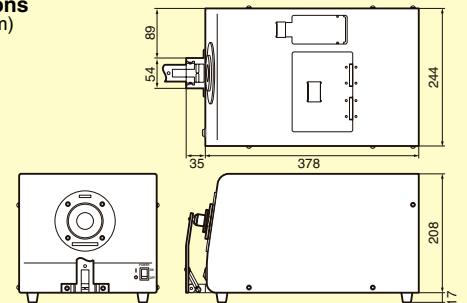

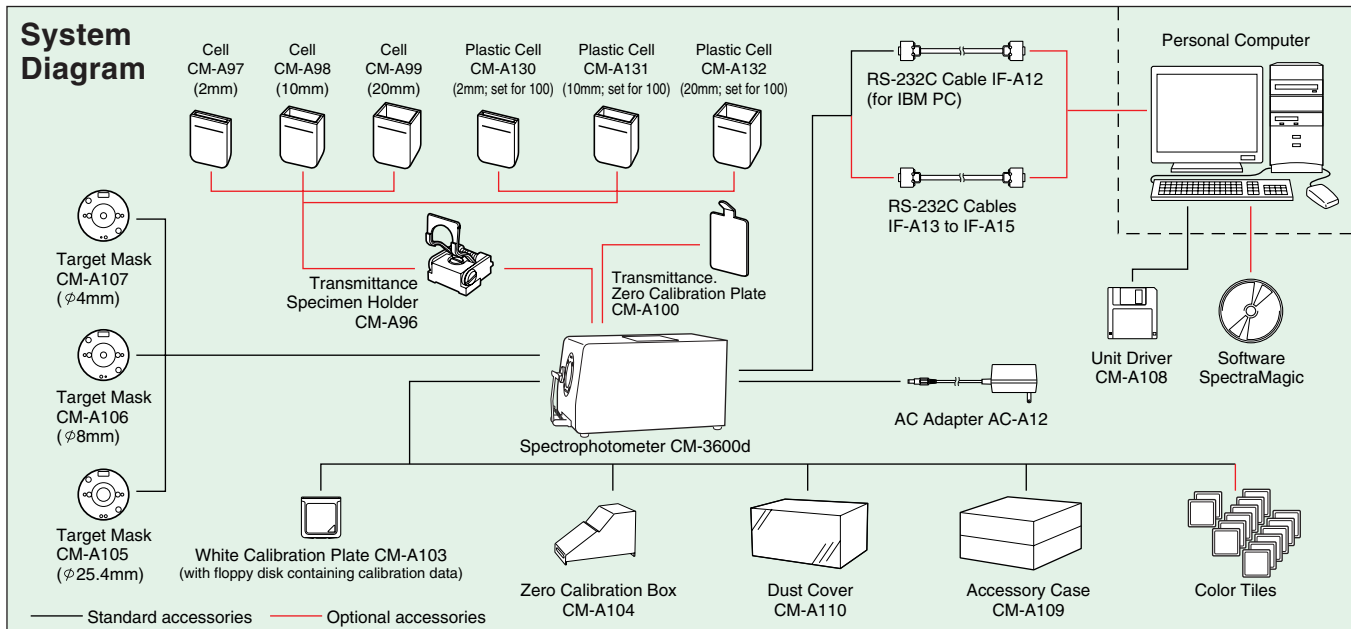

Specifications

Illumination/ observation system	Reflectance; d/8 (diffused illumination, 8-degree viewing), equipped with simultaneous measurement of SCI (specular component included) / SCE (specular component excluded) Conforms to CIE No.15, ISO7724/1, ASTM E1164, DIN5033 Teil7 and JIS Z8722 condition C standard. Transmittance : d/0 (diffused illumination, 0-degree viewing) Conforms to CIE No.15, ASTM E1164 and DIN5033 Teil7 standard.
Light-receiving element	Silicon photodiode array (dual 40 elements)
Spectral separation device	Diffraction grating
Wavelength range	360 to 740nm
Wavelength pitch	10nm
Half bandwidth	Approx. 10nm
Reflectance range	0 to 200%; resolution: 0.01%
Sphere size	φ152mm
Light source	Pulsed xenon lamps (x4)
Measurement time	Approx. 1.5 seconds
Minimum interval between measurements	Approx. 4 seconds; when SCI/SCE measured
Measurement/ illumination area	LAV : φ25.4mm/φ30mm MAV : φ8mm/φ11mm (Selectable) SAV : φ4mm/φ7mm
Repeatability	Spectral reflectance: Standard deviation within 0.1% Colorimetric values: Standard deviation within ΔE*ab0.02
Inter instrument agreement	Mean ΔE*ab0.15 (LAV/SCI) based on 12 BCRA Series II color tiles compared to values measured with master body.
Temperature dependence	Spectral reflectance: Within ±0.10%/°C Color difference: Within ΔE*ab 0.05/°C
UV adjustment	Instantaneous numerical adjustment
UV cut filter	400nm cutoff and 420nm cutoff
Transmittance chamber	Width: 133mm; depth: approx. 50mm; measurement dia.: approx. 17mm Transmission sample holder (Optional accessory): Sample holder; for both plate-shaped and liquid samples (removable)
Interface	RS-232C, D-SUB 9-pin (female) terminal
Power	AC120V/230V 50/60Hz (Using included AC adapter)
Operating temperature/ humidity range	13 to 33°C, relative humidity 80% or less (at 33°C) with no condensation
Storage temperature/ humidity range	0 to 40°C, relative humidity 80% or less (at 33°C) with no condensation
Size (W x H x D)/weight	244 x 208 x 378 mm (9-5/8 x 8-3/16 x 14-7/8 inch), 12 kg (26-7/16 lb.)
Standard accessories	White Calibration Plate, Target Mask (φ4mm), Target Mask (φ8mm), Target Mask (φ25.4mm), Zero Calibration box, AC adapter, Dust Cover, Accessory Case, Unit Driver, RS-232C Cable (9-pin, 2m)
Options	SpectraMagic (software), Transmittance Specimen Holder, Cell (2mm) / (10mm) / (20mm), Transmittance Zero Calibration Plate, RS-232C Cable (IBM, PC/AT 5m) / (IBM, PS/2 2m) / (IBM, PS/2 5m)

Network construction for color control either within an organization or between organizations

High inter-instrument agreement between the same Konica Minolta model and also among all CM models (benchtops and portables): CM-2000 series, CM-3000 series, This inter-instrument agreement is ideal when multiple units will be used for color control either within an organization or between organizations.

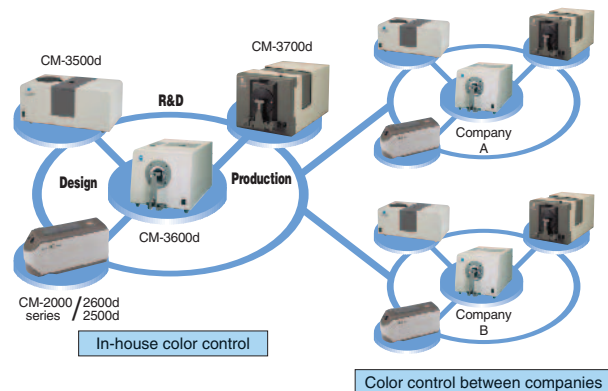

KONICA MINOLTA SPECTROPHOTOMETER LINEUP

- | | |
|------------------------|-------------------------------------|
| CM-3700d series | "State of the Art" Reference models |
| CM-3600d | Laboratory and Production model |
| CM-3500d | Unique Top Port bench-top model |
| CM-2600d/2500d | Top class accuracy portables |

SAFETY PRECAUTIONS

To ensure correct use of the instrument, please adhere to the following.



- Before using the instrument, be sure to read the instruction manual.
- Always use the specified power. Use of inappropriate power may result in fire or electric shock.



The manufacturing center of Konica Minolta Sensing Inc. (Location: Aichi Pref., Japan) was approved by the British certification organization Lloyd's Register Quality Assurance for certification under the ISO 9001: 1994 international quality management system standards on March 3, 1995. Since its establishment in 1990, the center has carried out the development and production of precision instruments and associated application software for the measurement of color, light, and shape. Certification was awarded to the center's quality management system, including design, manufacturer, management of manufacture, calibration and servicing. Certification was carried over to the ISO 9001: 2000 standards in February, 2003.

KONICA MINOLTA SENSING, INC.

Konica Minolta Photo Imaging U.S.A., Inc.
Konica Minolta Photo Imaging Canada, Inc.
Konica Minolta Photo Imaging Europe GmbH
Konica Minolta Photo Imaging France S.A.S.
Konica Minolta Photo Imaging UK Ltd.
Konica Minolta Photo Imaging Austria GmbH
Konica Minolta Photo Imaging Benelux B.V.
Konica Minolta Photo Imaging (Schweiz) AG
Konica Minolta Business Solutions Italia S.p.A.
Konica Minolta Photo Imaging Svenska AB
Konica Minolta Photo Imaging (HK) Ltd.
Shanghai Office
Konica Minolta Photo Imaging Asia HQ Pte Ltd.
KONICA MINOLTA SENSING, INC. Seoul Office

3-91, Daisennishimachi, Sakai, Osaka 590-8551, Japan

725 Darlington Avenue, Mahwah, NJ 07430, U.S.A. Phone: 888-473-2656 (in USA), 201-529-6060 (outside USA) FAX: 201-529-6070
 1329 Meyerside Drive, Mississauga, Ontario L5T 1C9, Canada Phone: 905-670-7722 FAX: 905-795-8234
 Europaallee 17, 30855 Langenhagen, Germany Phone: 0511-740440 FAX: 0511-741050
 Paris Nord II, 385, rue de la Belle-Etoile, B.P. 50077, F-95948 Roissy C.D.G. Cedex, France Phone: 01-49386550 / 01-30866161 FAX: 01-48638069 / 01-30866280
 Precedent Drive, Rooksley Park, Milton Keynes United Kingdom Phone: 01-908200400 FAX: 01-908618662
 Amalienstrasse 59-61, 1131 Vienna, Austria Phone: 01-87882-430 FAX: 01-87882-431
 Postbus 6000, 3600 HA Maarssen, The Netherlands Phone: 030-2470860 FAX: 030-2470861
 Riedstrasse 6, 8953 Dietikon, Switzerland Phone: 01-7403727 FAX: 01-7422350
 Via Stephenson 37, 20157, Milano, Italy Phone: 02-39011-1 FAX: 02-39011-219
 Solnastrandvägen 3, P.O. Box 9058 S-17109, Solna, Sweden Phone: 08-627-7650 FAX: 08-627-7685
 Room 1818, Sun Hung Kai Centre, 30 Harbour Road, Wanchai, Hong Kong Phone: 852-34137508 FAX: 852-34137509
 Rm 1211, Ruijin Building No.205 Maoming Road (S) Shanghai 20020, China Phone: 021-64720496 FAX: 021-64720214
 10, Teban Gardens Crescent, Singapore 608923 Phone: +65 6563-5533 FAX: +65 6560-9721
 801, Chung-Jin Bldg., 475-22, Bangbae-Dong, Seocho-ku, Seoul, Korea Phone: 02-523-9726 FAX: 02-523-9729