

Non-contact measurement of a wide variety of display types, such as LCDs, etc.

DISPLAY COLOR ANALYZER

CA-210 NEW

Universal Measuring Probe

Small Universal Measuring Probe

xyLv T_{uv}Lv RGB u'vLv XYZ

Select the probe among the following four types.

For LCD flicker measurement, use the LCD Flicker Measuring Probe or Small LCD Flicker Measuring Probe (see other side).

■ Universal Measuring Probe (Measurement area φ27 mm / Cable length: 2 m) **CA-PU12**

■ Universal Measuring Probe (Measurement area φ27 mm / Cable length: 5 m) **CA-PU15**

■ Small Universal Measuring Probe (Measurement area φ10 mm / Cable length: 2 m) **CA-PSU12**

■ Small Universal Measuring Probe (Measurement area φ10 mm / Cable length: 5 m) **CA-PSU15**

Up to five probes can be connected to a single main body. Universal Measuring Probes, Small Universal Measuring Probes, LCD Flicker Measuring Probes and Small LCD Flicker Measuring Probes can be connected simultaneously to a single main body.

(To connect multiple probes, the optional four-point extension board (CA-B14) is necessary.)



Photo shows Universal Measuring Probe

Applications

Rear Projector, PDP, LCD, OLED, FED
 Chromaticity Inspection / Adjustment
 Quality Control of Chromaticity.
 White-Balance Inspection / Adjustment
 Gamma Inspection / Adjustment.
 Contrast Inspection / Adjustment

FASTER

- The luminance and chromaticity of display can be measured as fast as 20 times per second (maximum), enabling faster Gamma measurement.

ACCURATE

- Accuracy of ±0.002 for White, ±0.004 for R,G,B. (Chromaticity)
- CIE 1931 Standard Observer XYZ Filter.
- Matrix measurement enables high accuracy for not just white, but for monochrome colors as well.

LOW LUMINANCE

- Precise measurement can be obtained at low luminance, enabling lower luminance and high-accuracy contrast measurement.
 Range of luminance for chromaticity measurement
 : 0.1 to 1000 cd/m² (Universal Measuring Probe)
 0.3 to 3000 cd/m² (Small Universal Measuring Probe)

EASY TO USE

- The measurement position can be easily confirmed by pointing function.
- Short measuring distance of 30 mm enables compact measuring system.
- Precise measurement can be obtained without the influence of the outside light by short measuring distance and the rubber hood (standard accessory).
- Special optical design limits acceptance within narrow angle of aperture. It eliminates the influence of viewing. Acceptance angle: ±2.5° (Universal Measuring Probe) , ±5° (Small Universal Measuring Probe)
- 4-digit display for chromaticity enables more precise data readings.
- Expandable up to 5 measuring probes. (Requires expansion board CA-B14)
- USB connection provided as standard, so it can be connected even to computers without serial ports.

Non-contact measurement of color and flicker for active-drive LCDs.

LCD Flicker Measuring Probe is applied to the "Flicker measuring function". Because of this it is not able to measure the display whose emission intensity fluctuates in single frame scanning period.

DISPLAY COLOR ANALYZER

CA-210

LCD Flicker Measuring Probe

Small LCD Flicker Measuring Probe

Same model as CA-210 measuring probes sold until May 2003.

xyLv TΔuvLv RGB u'v'Lv XYZ FLIC.

Select the probe among the following four types.

■ LCD Flicker Measuring Probe **CA-P12**
(Measurement area φ27 mm / Cable length: 2 m)

■ LCD Flicker Measuring Probe **CA-P15**
(Measurement area φ27 mm / Cable length: 5 m)

■ Small LCD Flicker Measuring Probe **CA-PS12**
(Measurement area φ10 mm / Cable length: 2 m)

■ Small LCD Flicker Measuring Probe **CA-PS15**
(Measurement area φ10 mm / Cable length: 5 m)

Up to five probes can be connected to a single main body. Universal Measuring Probes, Small Universal Measuring Probes, LCD Flicker Measuring Probes and Small LCD Flicker Measuring Probes can be connected simultaneously to a single main body.
(To connect multiple probes, the optional four-point extension board (CA-B14) is necessary.)

A basic model with CA-100 compatible mode for contact measurements of the color of various types of displays, as CRTs, PDPs.

CRT COLOR ANALYZER

CA-100Plus

Measuring Probe

High luminance Measuring Probe

Please request a CA-100Plus catalog for further information.

xyLv TΔuvLv RGB u'v'Lv XYZ

Select the probe among the following four types.

■ Measuring Probe **CA-P02**
(Cable length: 2 m)

■ Measuring Probe **CA-P05**
(Cable length: 5 m)

■ High luminance Measuring Probe **CA-PH02**
(Cable length: 2 m)

■ High luminance Measuring Probe **CA-PH05**
(Cable length: 5 m)

Up to five probes can be connected to a single main body. Measuring Probes and High luminance Measuring Probes can be connected simultaneously to a single main body.
(To connect multiple probes, the optional four-point extension board (CA-B04) is necessary.)

Applicability of CA series for different display types

This table is based on the most popular method for controlling emission intensity for each display type.

(※1) Measurements of displays using certain control methods are not possible. For details of measurement compatibility, contact your nearest Minolta representative.

Examples for which measurement is not possible:

- Displays which use PWM, etc. for control of emission intensity.
- Displays with backlights which emit intermittently.
- Displays which write black for each frame, etc.

(※2) Although the CA-100Plus can handle the emission intensity variation, the instrument has a wide acceptance angle which makes it unsuitable for measurements of LCDs with strong viewing-angle dependency.

○ Recommended

△ Measurement possible with restrictions, but probes marked with ○ are recommended

× Measurement not possible

		CA-210				
		Standard measurements	LCD flicker measurements			
		Universal Measuring Probe CA-PU12 / CA-PU15	Small Universal Measuring Probe CA-PSU12 / CA-PSU15	LCD Flicker Measuring Probe CA-P12 / CA-P15	Small LCD Flicker Measuring Probe CA-PS12 / CA-PS15	
Transmissive / semi-transmissive LCD	Active Matrix Driven	○	○	○ (※1)	○ (※1)	
	Passive Matrix Driven	○	○	×	×	
Rear Screen Projector	LCD	Active Matrix Driven	○	△	○ (※1)	△ (※1)
		Passive Matrix Driven	○	△	×	×
	DLP CRT		○	△	×	×
			○	△	×	×
OLED	Active Matrix Driven	○	○	○ (※1)	○ (※1)	
	Passive Matrix Driven	○	○	×	×	
PDP		○	△	×	×	
FED		○	○	×	×	

LCD Flicker Measuring Probe and Small LCD Flicker Measuring Probe are unsuitable for Measurements of CRTs.

Optical System Features

The CA-210 uses a special optical system suitable for providing measurements of LCD panels.

The main components of the optical system are the objective lens, optical fiber block, on-chip lenses, and sensor. The light from the light source is focused onto the receiving window of the optical fiber block. The focused light is mixed inside the optical fiber block and split into 3 parts, which are then guided to the receiving areas of the x, y, z sensors. Here, the light is further focused by the on-chip lenses onto the sensors themselves.

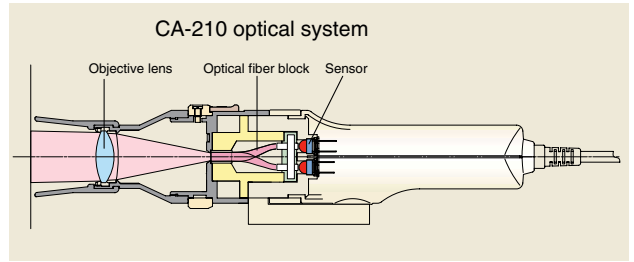

Low-Luminance Measurement

A key point in making it possible to accurately take measurements at low-luminance levels is to minimize the light loss in guiding the received light to the sensors.

In a conventional system, the received light passes through the objective lens and is focused immediately on the 3 sensors (x, y, z sensors). A problem with this method is that some of the light is focused on areas other than the sensor, so the light loss is large.

The CA-210 uses optical fibers, so the light loss due to transmission of the light to the sensors is relatively low compared to conventional methods. Specifically, the light received by the lens is focused on the optical fiber block receiving window. The light then passes through optical fibers directly to on-chip lenses, which focus the light onto the sensors. As a result of this, light transmission loss is eliminated and measurements at low luminance levels are made possible.

Optical system of conventional measuring instruments

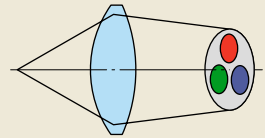

Narrow Viewing Angle/Uniform Viewing Angle

When a person looks at a display, they view the emitted light within a relatively narrow angle. Because of this, in order to obtain measured values which correspond well with the luminance and chromaticity perceived by a person, it is necessary for the measuring instrument to have the same narrow viewing angle. In addition, since LCDs have viewing-angle characteristics, measurements at different viewing angles will result in different measured values. IEC 61747-6, which defines the measurement method for LCDs, specifies that the viewing angle of the measuring instrument for evaluating LCDs should be within 5°. (The viewing angle is shown by θ_1 , θ_2 , θ_3 and ψ_1 , ψ_2 , ψ_3 .)

The CA-210 has a viewing angle of 5°, and so meets the requirements of the IEC standard. For a conventional measuring instrument, when the measuring head has been set so that the measurement axis is perpendicular to the surface of the emitting surface of the measurement subject, differences in the measurement position do not result in great differences in the viewing angle itself (shown as θ_1 , θ_2 , θ_3 in the figure), but if we look at the incident angle relative to the normal to the emitting surface (shown as a dotted line in the figure), we see that the maximum angles (shown as θ'_1 and θ'_3 in the diagram) are very different. At the edges of the measurement area, light from far outside the viewing angle is received.

Measurement position and incident angle of conventional instrument

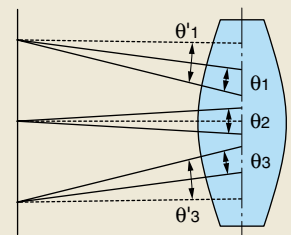

By using a special optical system in the CA-210, the angle of the received light is symmetrical about the normal to the emitting surface for every point within the measuring area ($\phi 27$ mm). Since the viewing angle of the CA-210 is 5°, the light received would be only the light within $\pm 2.5^\circ$ relative to the normal to the emitting surface (shown as a dotted line in the figure).

Measurement position and incident angle of CA-210

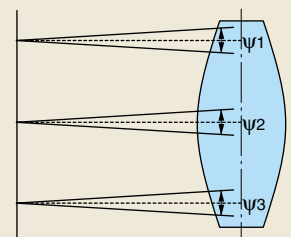

System Diagram

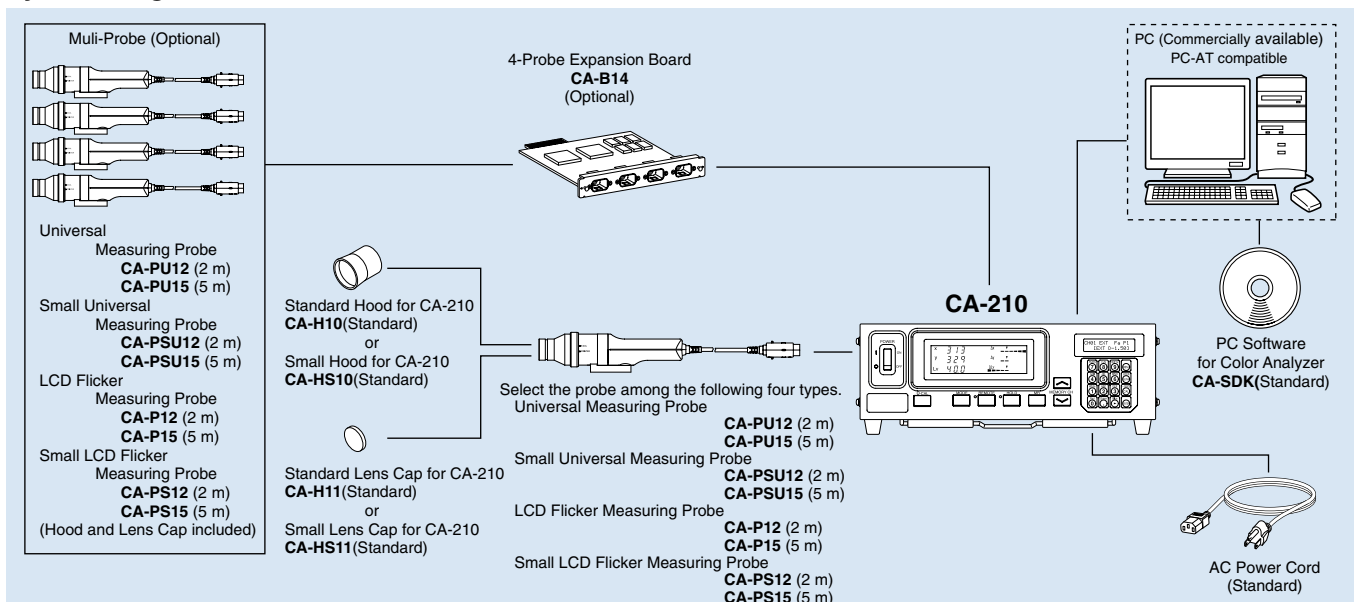

Construction of Gamma Adjustment System

This is an example of gamma adjustment system. User can create adjustment system by PC Software for Color Analyzer CA-SDK which comes as standard accessory. Software controls CA-210 and pattern generator to obtain color and chromaticity data with each output level. After calculating correction factor of gamma curve, software will write the look up table of coefficient to monitor firmware.

The white balance adjustment system can be constructed by a similar method.

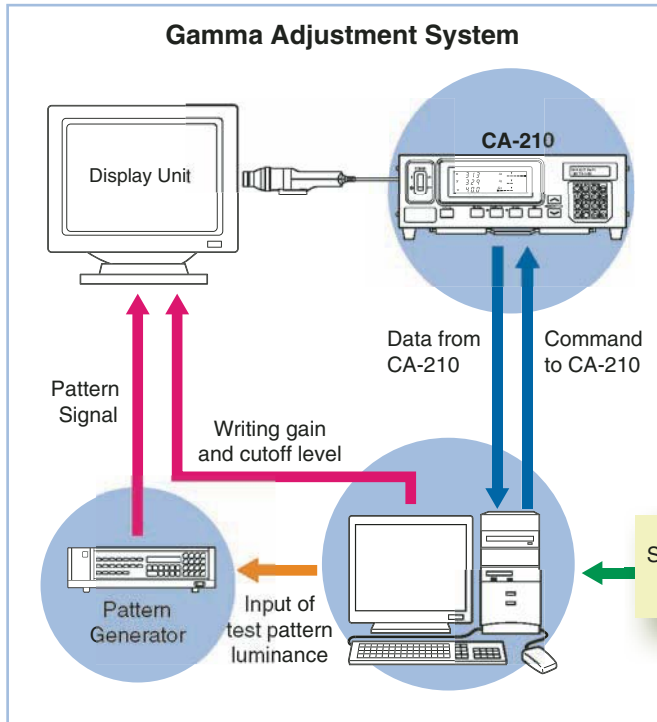

Matrix Calibration

User's own matrix correction factor is set to the memory channels by measuring three monochrome colors (R, G, B and W) of known values and setting the obtained calibration values (xyLv) and emission characteristic to the instrument. Once this factor is set, the measured values will be displayed after correction by this factor and output each time measurement is taken.

Performing matrix calibration enables high-accuracy measurements of displays that provide colors through additive color mixing of three monochrome colors (R, G and B). Since the matrix correction factor obtained from Minolta's calibration standard has been set, measured values calculated based on this factor will be acquired when this instrument is used for the first time since shipment from the factory.

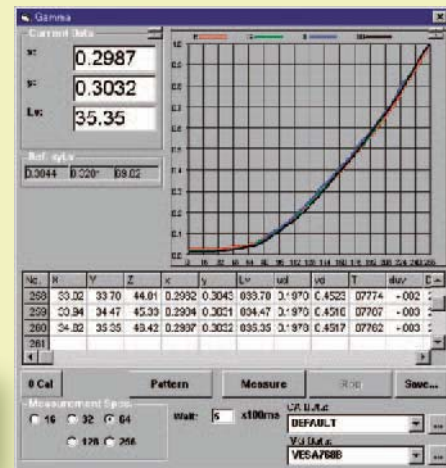

Sample software Gamma

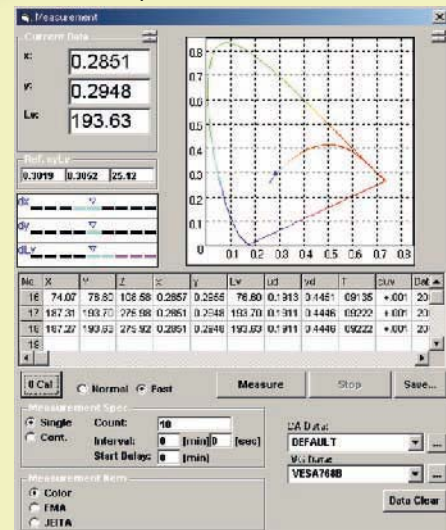

Sample software Color

Sample software (Standard)

Cal

CA-210 can be corrected in the matrix calibration method using Konica Minolta's spectroradiometer CS-1000A.

Color

The measurement data of CA-210 can be acquired into the PC. Drift tests, LCD stability test and so on can be performed easily. The acquired data can be read with Excel[®] or other spreadsheet software.

Contrast

Multi-point measurement (5, 9, or 25 points) can be made for white uniformity and contrast measurement.

Gamma

R, G, B, and W gamma measurements for gradations of 16, 32, 64, 128, and 256 steps.

PC Software for Color Analyzer CA-SDK (Standard accessory)

Standard accessory SDK helps create software easily according to needs. Sample software is bundled; you can start data collection easily.

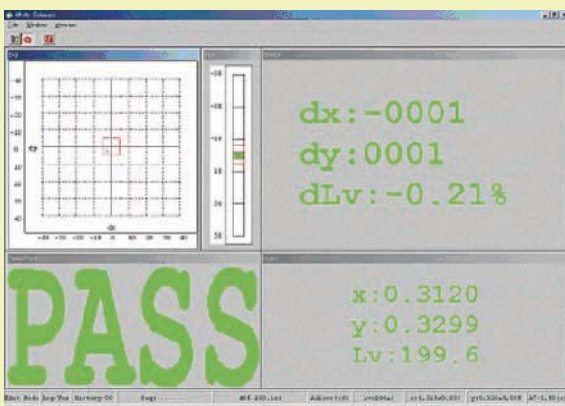

Example of White Balance Adjustment Software made by SDK

Required system

OS : Windows[®] 98,2000,ME,XP

Windows[®] and Excel[®] are a trademark of Microsoft Corporation in the USA and other countries.

Dimensions (Units : mm)

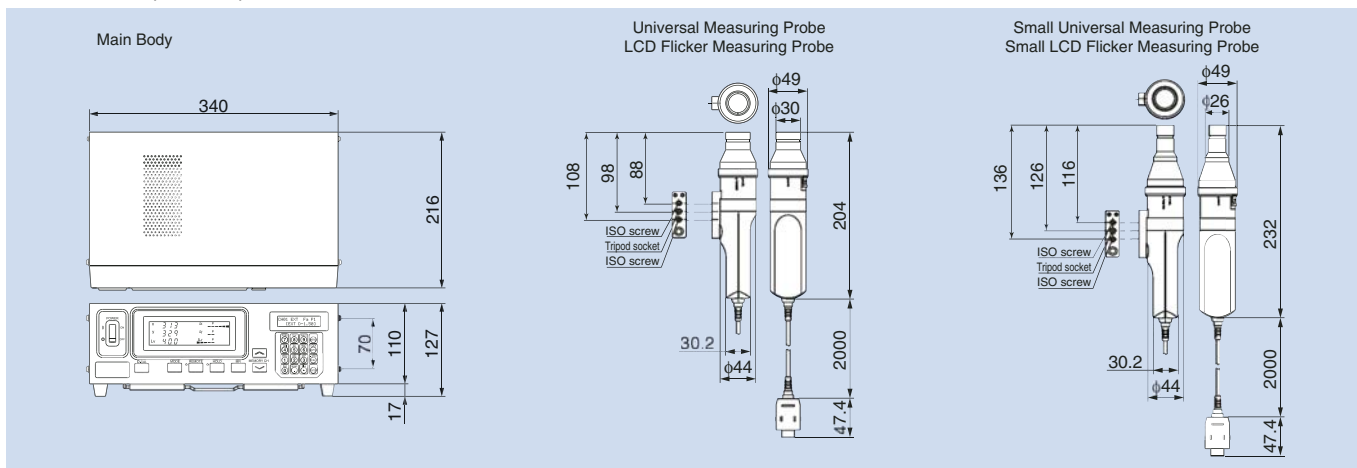

Specifications

Item	CA-210 (Universal Measuring Probe)	CA-210 (Small Universal Measuring Probe)	CA-210 (LCD Flicker Measuring Probe)	CA-210 (Small LCD Flicker Measuring Probe)
Receptor	Detector: Silicon photo cell			
Measurement area	φ27 mm	φ10 mm	φ27 mm	φ10 mm
Acceptance angle	±2.5	±5	±2.5	±5
Pointing function	By LED			
Measurement distance	30±10 mm	30±5 mm	30±10 mm	30±5 mm
Display range	Luminance 0.01 to 1000 cd/m ²	0.01 to 3000 cd/m ²	0.01 to 1000 cd/m ²	0.01 to 3000 cd/m ²
	Chromaticity Displayed in 4 or 3-digit value (Can be chosen)			
Luminance	Measurement range 0.10 to 1000 cd/m ²	0.30 to 3000 cd/m ²	0.10 to 1000 cd/m ²	0.30 to 3000 cd/m ²
	Accuracy (for white)*1 ±2%±1 digit of reading (temperature : 23°C±2°C, relative humidity : (40±10)%)	0.2%±1 digit 0.1%±1 digit	0.2%±1 digit 0.1%±1 digit	0.2%±1 digit 0.1%±1 digit
	Repeatability(2σ) ±1	±0.008 for white ±0.005 for white ±0.003 for white ±0.002 for white	±0.008 for white ±0.005 for white ±0.003 for white ±0.002 for white	±0.008 for white ±0.005 for white ±0.003 for white ±0.002 for white
Chromaticity	Measurement range 0.10 to 1000 cd/m ²	0.30 to 3000 cd/m ²	0.10 to 1000 cd/m ²	0.30 to 3000 cd/m ²
	Accuracy*1 (temperature : 23°C±2°C, relative humidity : (40±10)%)	±0.008 for white ±0.005 for white ±0.003 for white ±0.002 for white	±0.008 for white ±0.005 for white ±0.003 for white ±0.002 for white	±0.008 for white ±0.005 for white ±0.003 for white ±0.002 for white
	Repeatability*1 ±1	±0.015 (2σ) ±0.008 (2σ) ±0.003 (2σ) ±0.001 (2σ)	±0.015 (2σ) ±0.008 (2σ) ±0.003 (2σ) ±0.001 (2σ)	±0.015 (2σ) ±0.008 (2σ) ±0.003 (2σ) ±0.001 (2σ)
Flicker Contrast method	Measurement range	—	5 cd/m ² or higher 0.0 to 100 %	15 cd/m ² or higher
	Display range	—	—	—
	Accuracy	—	±1 % (Flicker frequency: 30 Hz AC/DC 10 % sine wave) ±2 % (Flicker frequency: 60 Hz AC/DC 10 % sine wave)	—
	Repeatability	—	1 % (2σ) (Flicker frequency: 20 to 65 Hz AC/DC 10 % sine wave)	—
Flicker JEITA method*3	Measurement range	—	5 cd/m ² or higher	15 cd/m ² or higher
	Accuracy	—	±0.5 dB (Flicker frequency: 30 Hz AC/DC 10 % sine wave) ±0.3 dB (2σ) (Flicker frequency: 30 Hz AC/DC 10 % sine wave)	—
	Repeatability	—	—	—
Measurement speed (measurements/sec.)	xyLv*4 5 (4.5) 0.10 to 3.99 cd/m ² 20 (17) 4.00 cd/m ² or higher	5 (4.5) 0.30 to 11.99 cd/m ² 20 (17) 12.00 cd/m ² or higher	5 (4.5) 0.10 to 1.99 cd/m ² 20 (17) 2.00 cd/m ² or higher	5 (4.5) 0.30 to 5.99 cd/m ² 20 (17) 6.00 cd/m ² or higher
	Flicker Contrast	—	16 measurements/sec. (16 measurements/sec.)	—
	Flicker JEITA*3	—	0.5 measurements/sec. (0.3 measurements/sec.) *5	—
Display	Digital xyLv, XYZ, TΔuvLv, u'v'Lv, RGB analyze Chromaticity is displayed up to fourth decimal place. (Three-digit indication can be chosen.)	—	xyLv, XYZ, TΔuvLv, u'v'Lv, RGB analyze Chromaticity is displayed up to fourth decimal place. (Three-digit indication can be chosen.)	—
	Analog LCD ΔxΔyΔLv, R/G B/G ΔG, ΔR B/R G/R 16 characters by 2 lines (with backlight)	—	ΔxΔyΔLv, R/G B/G ΔG, ΔR B/R G/R, Flicker (Contrast method) *3	—
SYNC mode	NTSC, PAL, EXT, UNIV, INT			
Object under measurement	Vertical synchronizing frequency: 40 to 200 Hz		Vertical synchronization frequency: 40 to 200 Hz (Luminance or chromaticity measurement), 40 to 130 Hz (Flicker measurement)	
Memory channel	100 channels			
Analyzer function	Standard function			
Interface	RS-232C (38,400 bps or below), USB (Rev.1.1)			
Multi-point Measurement	Max. 5 points(Use 4-Probe Expansion Board CA-B14)			
Software	SDK software (supplied as standard accessory)			
Operating temperature/humidity range	Temperature : 10 to 28°C; relative humidity 70 % or less with no condensation Luminance change : ±2 % ±1 digit of reading for white Chromaticity change ±0.002 for white, ±0.006 for monochrome from reading of Konica Minolta's standard LCD*1, 160.0 cd/m ² , with 23°C 40 %			
Storage temperature/humidity range	0 to 28°C : relative humidity 70 % or less with no condensation 28 to 40°C : relative humidity 40 % or less with no condensation			
Input voltage range	100 ~ 240 V~, 50-60 Hz, 50 VA			
Size	Main body: 340 (W) × 127 (H) × 216 (D) mm, Probe: φ49 × 204 mm	Main body: 340 (W) × 127 (H) × 216 (D) mm, Probe: φ49 × 232 mm	Main body: 340 (W) × 127 (H) × 216 (D) mm, Probe: φ49 × 204 mm	Main body: 340 (W) × 127 (H) × 216 (D) mm, Probe: φ49 × 232 mm
Weight	Main body: 3.58 kg, Probe: 520 g		Main body: 3.58 kg, Probe: 540 g	

*1 : The chromaticity and luminance are measured under Konica Minolta's condition (standard LCD(6500 K, 9300 K) is used).
 *2 : The luminance for monochrome is measured when the reading of luminance for white is 160 cd/m².
 *3 : Measurement of flicker (JEITA method) is supported by SDK software.
 *4 : Measuring probe connected to probe connector P1 only, used USB (used RS-232C Baud rate: 38400 bps)
 *5 : Measured by Konica Minolta's PC (P3-600 MHz)
 • Specifications are subject to change without notice.

SAFETY PRECAUTIONS

To ensure correct use of the instrument, please adhere to the following.



- Before using the instrument, be sure to read the instruction manual.
- Always use the specified power. Use of inappropriate power may result in fire or electric shock.



The manufacturing center of Konica Minolta Sensing Inc. (Location: Aichi Pref., Japan) was approved by the British certification organization Lloyd's Register Quality Assurance for certification under the ISO 9001: 1994 international quality management system standards on March 3, 1995. Since its establishment in 1990, the center has carried out the development and production of precision instruments and associated application software for the measurement of color, light, and shape. Certification was awarded to the center's quality management system, including design, manufacturer, management of manufacture, calibration and servicing. Certification was carried over to the ISO 9001: 2000 standards in February, 2003.

KONICA MINOLTA SENSING, INC.

Konica Minolta Photo Imaging U.S.A., Inc.
 Konica Minolta Photo Imaging Canada, Inc.
 Konica Minolta Photo Imaging Europe GmbH
 Konica Minolta Photo Imaging France S.A.S.
 Konica Minolta Photo Imaging UK Ltd.
 Konica Minolta Photo Imaging Austria GmbH
 Konica Minolta Photo Imaging Benelux B.V.
 Konica Minolta Photo Imaging (Schweiz) AG
 Konica Minolta Business Solutions Italia S.p.A.
 Konica Minolta Photo Imaging Svenska AB
 Konica Minolta Photo Imaging (HK) Ltd.
 Shanghai Office
 Konica Minolta Photo Imaging Asia HQ Pte Ltd.
 KONICA MINOLTA SENSING, INC. Seoul Office

3-91, Daisennishimachi, Sakai.Osaka 590-8551, Japan

725 Darlington Avenue, Mahwah, NJ 07430, U.S.A. Phone: 888-473-2656 (in USA), 201-574-4000 (outside USA) FAX: 201-574-4201
 1329 Meyerside Drive, Mississauga, Ontario L5T 1C9, Canada Phone: 905-670-7722 FAX: 905-795-8234
 Europaallee 17, 30855 Langenhagen, Germany Phone: 0511-7404-895 FAX: 0511-7404-809
 Paris Nord II, 385, rue de la Belle-Etoile, B.P. 50077, F-95948 Roissy C.D.G. Cedex, France Phone: +33-1-49 38 25 19 FAX: +33-1-49 38 47 71
 7-9 Tanners Drive, Blakelands North, Milton Keynes, MK14 5BU, United Kingdom Phone: +44 (0) 1908 283 939 FAX: +44 (0) 1908 618 662
 Amalienstrasse 59-61, 1131 Vienna, Austria Phone: 01-87882-430 FAX: 01-87882-431
 Postbus 6000, 3600 HA Maarssen, The Netherlands Phone: 030-2470860 FAX: 030-2470861
 Riedstrasse 6, 8953 Dietikon, Switzerland Phone: +41 43 322 97 40 FAX: +41 43 322 97 49
 Via Stephenson 37, 20157, Milano, Italy Phone: 02-39011-1 FAX: 02-39011-219
 Solna strandväg 3, P.O.Box 9058 S-17109, Solna, Sweden Phone: 08-627-7650 FAX: 08-627-7685
 Room 1818, Sun Hung Kai Centre, 30 Harbour Road, Wanchai, Hong Kong Phone: 852-34137508 FAX: 852-34137509
 Rm 1211, Ruijin Building No.205 Maoming Road (S) Shanghai 20020, China Phone: 021-64720496 FAX: 021-64720214
 10, Teban Gardens Crescent, Singapore 608923 Phone: +65 6563-5533 FAX: +65 6560-9721
 801, Chung-Jin Bldg., 475-22, BangBae-Dong, Seocho-ku, Seoul, Korea Phone: 02-523-9726 FAX: 02-523-9729